

# Concrete Batching Plants



**FABO<sup>®</sup>**

# Crushing Screening Plants



# Concrete Batching Plant

## TWS-06 Twinshaft Mixer

MODEL	TWS-06
WET CONCRETE CAPACITY	6,0 m <sup>3</sup>
GEARBOX	DIŞSAN - PDS
FEEDING CAPACITY	9000 LT
FRESH CONCRETE CAPACITY	7500 LT
COMPACTED CONCRETE CAPACITY	6000 LT
MOTOR POWER	2x110kW
DISCHARGE TYPE	HYDRAULIC DOOR
AUTOMATIC LUBRICATION	YES

DIMENSION	TWS-06
A	2600 mm
B	6200 mm
C	4650 mm
D	3720 mm
E	2960 mm

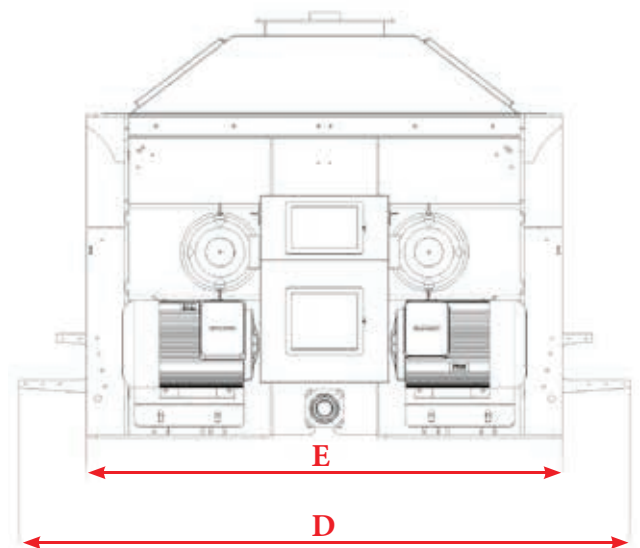
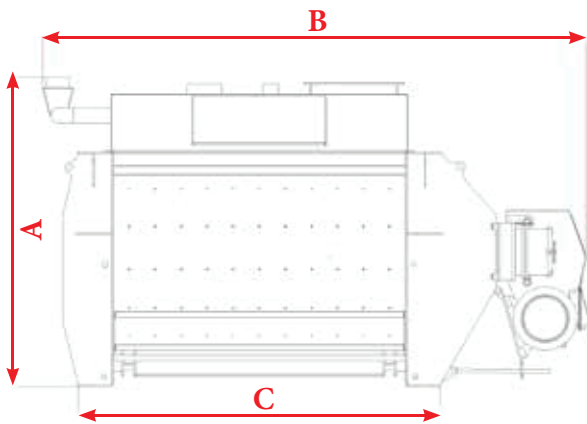

## MIXING ELEMENTS

Mixer tank, mixer blades are lined with Ni-Hard. Low profile mixing arms are made of Cast Iron to prevent material buildup. The positions and directions of its numerous blades guarantee the correct combination between rolling and circulation of the material during the mixing process.

## GEAR BOX

The gearboxes of the FABO Twinshaft mixing group are planetary type and the first drive is driven by a pulley transmission equipped with a constant velocity universal joint to keep the shafts synchronized. The low initial speed of the gearboxes ensures that the lubricating oil works healthier. The connection between the gearbox and the tank is made with the special coupling sleeve developed over the years to make any possible maintenance to the shaft supports easier and faster.

This sleeve (coupling apparatus) can be easily removed to provide access to the shaft support, minimizing downtime for the plant in case of maintenance.



## Contact:



[fabo@hidro-rad.hr](mailto:fabo@hidro-rad.hr)



+ (385) 21 721 041

