

Concrete Batching Plants



FABO[®]

Crushing Screening Plants



FABO Mobile Crushing Plants

FABO, which sells crushing, screening and washing facilities to 7 continents, produces the most powerful crushers and sieves in the market. With its low maintenance costs, innovative designs and 17 years of experience, it offers unique solutions to its customers.

Mobile crushers plants perform superiorly even in the harshest physical conditions and with their flexibility offer numerous advantages to business operating in different sectors. It combines all the equipment that needs to be found in a crusher facility on a single portable chassis.

Mobile crushers plants are designed to show high efficiency in the mining industry, waste recycling, and construction activities such as road construction. They are equipped with different crusher types that can meet all kinds of needs such as vertical shaft, crawler, impact and tertiary.

Our mobile solutions:

- Pro Series Mobile Crushing Plant
- MCK Series Mobile Hard Stone Crushing Plant
- Mobile Tertiary Crusher
- Mobile Crushing, Screening and Washing Plant
- Mobile Primary Crusher
- Mobile Secondary Crushing and Screening Plant
- Mobile Vertical Shaft Crusher
- Mobile Container Type Jaw Crusher
- Tracked Crusher Plant
- Tracked Screening Plant



MEY Series Mobile Screening Washing Plant



MEY-1645 Mobile Screening Washing Plant

MEY-1645 Mobile Screening Washing Plant is produced on a single chassis in the most ideal way for screening and washing the material by using a grizzly feeder bunker, vibrating screen and screw washer.

MEY-1645 Mobile Screening Washing Plant, which performs screening and washing duties on a single chassis, is the most popular screening & washing plant with its minimum area coverage and high performance.

MEY-1645 Mobile Screening & Washing Plant washes and separates 4 different sizes of products with 4 different stock belts and 1 screw washer on its body and is the number one solution partner for our customers.

MODEL	MEY-1645	DIMENSION	MEY-1645
PRODUCTION CAPACITY	120-200 Ton/Hour	A	13500 mm
VIBRATING SCREEN SIZE	1600x4500 mm	B	4500 mm
SCREW WASHER SIZE	600x6000 mm(Twin)	C	3600 mm
TOTAL MOTOR POWER	68 kW		
GENERATOR - OPTIONAL	130 kvA		

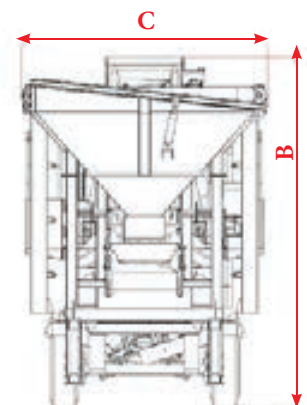
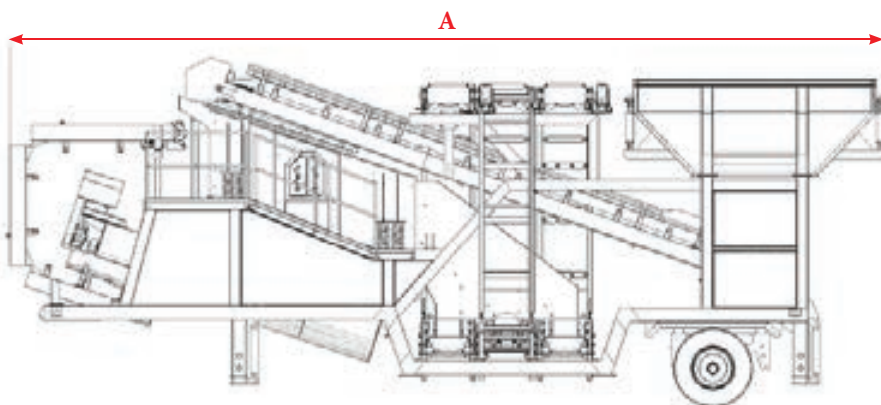



Shipping method

Fabo **MEY-1645 Mobile Screening Washing Plant** minimizes the time and cash loss of the user with its ease of transportation. The **MEY-1645 Mobile Screening Washing Plant** developed by our engineers can be easily moved on a single chassis with a truck. Fabo **MEY-1645 Mobile Screening Washing Plant** , which is moved on axles, is ready for transportation in 10 minutes.

The **MEY-1645 Mobile Screening Washing Plant**, which we have created as a result of 18 years of knowledge and work, has been designed in the most ideal way for the user with its crushing and screening capacity and easy transportation.

The brake system in the axle system has increased the life and property safety of the user to the highest level and has written its name in the sector with gold letters with 0% accident rate.

Fabo **MEY-1645 Mobile Screening Washing Plant**, which comes to the transport position without the need for manpower, is the leading crushing and screening plant in the sector with the highest transportation speed.

Contact:



fabo@hidro-rad.hr



+ (385) 21 721 041

