

# Concrete Batching Plants



**FABO**<sup>®</sup>

# Crushing Screening Plants



# FABO Mobile Crushing Plants

---

**FABO**, which sells crushing, screening and washing facilities to 7 continents, produces the most powerful crushers and sieves in the market. With its low maintenance costs, innovative designs and 17 years of experience, it offers unique solutions to its customers.

**Mobile crushers plants** perform superiorly even in the harshest physical conditions and with their flexibility offer numerous advantages to business operating in different sectors. It combines all the equipment that needs to be found in a crusher facility on a single portable chassis.

**Mobile crushers plants** are designed to show high efficiency in the mining industry, waste recycling, and construction activities such as road construction. They are equipped with different crusher types that can meet all kinds of needs such as vertical shaft, crawler, impact and tertiary.

**Our mobile solutions:**

- Pro Series Mobile Crushing Plant
- MCK Series Mobile Hard Stone Crushing Plant
- Mobile Tertiary Crusher
- Mobile Crushing, Screening and Washing Plant
- Mobile Primary Crusher
- Mobile Secondary Crushing and Screening Plant
- Mobile Vertical Shaft Crusher
- Mobile Container Type Jaw Crusher
- Tracked Crusher Plant
- Tracked Screening Plant



# Fullstar Serie Mobile Crushing Screening Washing Plant



## Fullstar-60 Mobile Crushing Screening Washing Plant

**Fullstar-60 Mobile Crushing Screening & Washing Plant** is produced on a single chassis including Feeding Bunker, Jaw Crusher, Tertiary Crusher, Vibrating Washing Screen, Spiral Washer, Stock and Feedback Conveyor Belts. **FULLSTAR-60** model is the number one solution partner of its users for crushing screening and washing on a single machine. It also brings a lot of advantages like ease maintenance, minimum required space, simple installation and maximum performance.

MODEL	Fullstar-60
PRODUCTION CAPACITY	60-100 Ton/Hour
VIBRATING SCREEN SIZE	1300x4000 mm
SCREW WASHER SIZE	Ø 500x5000 mm(Twin
JAW CRUSHER SIZE	600x400 mm
IMPACT CRUSHER ROTOR	Ø 1200x650 mm
MAXIMUM FEEDING SIZE	380 mm
TOTAL MOTOR POWER	232 kW
GENERATOR – OPTIONAL	250 kvA

# Fullstar Serie Mobile Crushing Screening Washing Plant

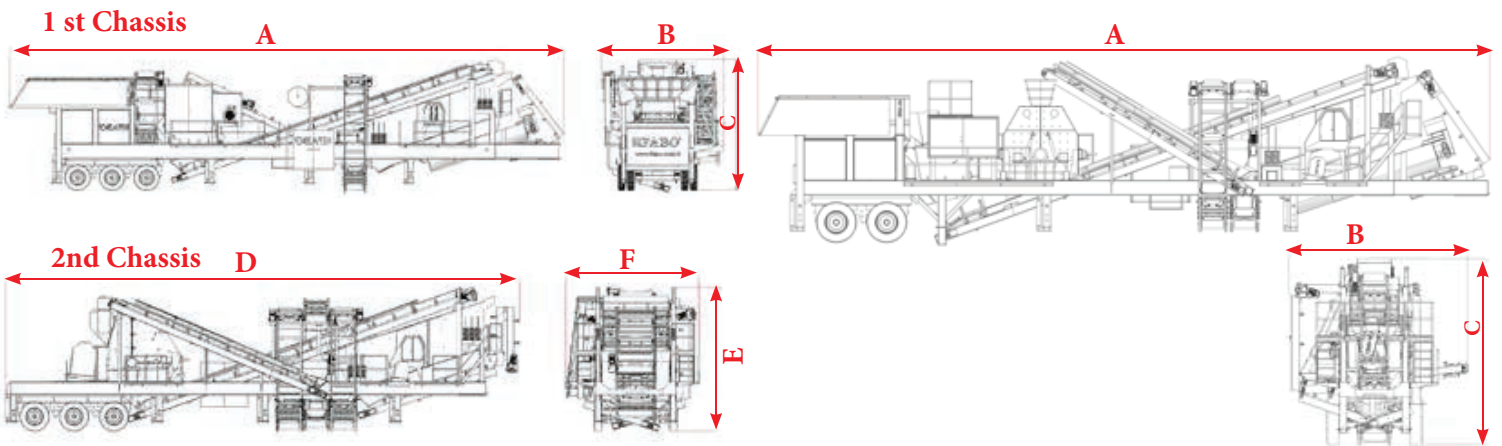

DIMENSION	Fullstar-60
A	21000 mm
B	4650 mm
C	4650 mm
D	-
E	-
F	-



### Shipping method

**Fabo Fullstar-60 Mobile Crushing Screening Washing Plant** minimizes the time and cash loss of the user with its ease of transportation. **The Fullstar-60 Mobile Crushing Screening Washing Plant** developed by our engineers can be easily moved on a single chassis with a truck. **Fabo Fullstar-60 Mobile Crushing Screening Washing Plant**, which is moved on axles, is ready for transportation in 10 minutes.

The **Fullstar-60 Mobile Crushing Screening Washing Plant**, which we have created as a result of 18 years of knowledge and work, has been designed in the most ideal way for the user with its crushing and screening capacity and easy transportation.

The brake system in the axle system has increased the life and property safety of the user to the highest level and has written its name in the sector with gold letters with 0% accident rate.

**Fabo Fullstar-60 Mobile Crushing Screening Washing Plant**, which comes to the transport position without the need for manpower, is the leading crushing and screening plant in the sector with the highest transportation speed.

### Contact:



[fabo@hidro-rad.hr](mailto:fabo@hidro-rad.hr)



+ (385) 21 721 041

