

# Concrete Batching Plants



**FABO**<sup>®</sup>

# Crushing Screening Plants



# FABO Stationary Crushing Plants

---

**FABO**, which sells crushing, screening and washing facilities to 7 continents, produces the most powerful crushers and sieves in the market. With its low maintenance costs, innovative designs and 17 years of experience, it offers unique solutions to its customers.

**Stationary crushing plants** have advanced equipment that provides high efficiency for mines, quarries and construction projects. Our crusher plants with different capacities are ideal for solutions suitable for every project.

**Stationary crushing plants** can be used for aggregate production in various sizes, for crushing hard mines and ores. To maximize your profits and improve your business volume, like companies around the world, choose FABO crushing, screening and washing facilities.

**Our stationary solutions:** Stationary Stone Crushing and Screening Plants

- Vibrating Bunkers
- Jaw Crushers
- Primary Impact Crushers
- Tertiary Crushers
- Vertical Shaft Crushers
- Cone Crushers
- Vibrating Screens
- Dewatering Screen
- Spiral Washers
- Bucket Washers
- Wobbler Feeder



# Cone Crushers



## CC-200 Cone Crushers

Cone crushers are designed to crush hard and abrasive stream and quarry materials such as granite, basalt and andesite. Thanks to the long-lasting wear parts, the cone crusher is lasts longer.

In addition, since maintenance and repair operations can be done easily on the crusher, operating costs are also low.

The crusher is also called “cone crusher” since the crushing process is done between conical surfaces. In terms of both size and structure, many different shapes are encountered today. In general, there are two main types as “movable shaft” and “fixed shaft”.

MODEL	CC-200
FEED OPENING	185 mm
CAPACITY	200-250 TPH
MOTOR POWER	100-132 kW
WEIGHT	11230 kg

DIMENSION	CC-200
A	2520 mm
B	2540 mm
C	1100 mm

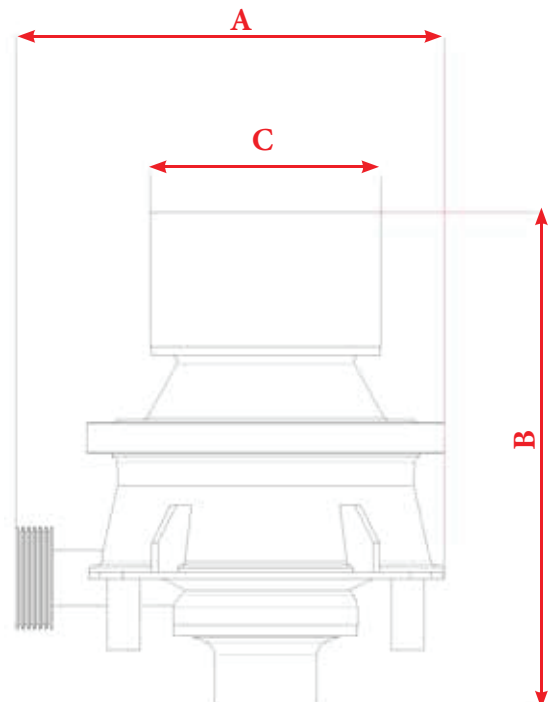

### General Specifications and Futures:

- Inner design protected against dust
- Option to use automatic or manual
- Easy setting possibilities
- Easy intervention and maintenance
- Operation from the control panel, stop, lubrication, hydraulic system and inlet width control



### Contact:



fabo@hidro-rad.hr



+ (385) 21 721 041

