

NEW!

ENGINE

Model	: DEUTZ TCD 4.1
Type	: Water cooled, 4 cycle, 4 cylinders, line type direct injection, turbocharger, intercooler, electronic diesel engine
Power	: 141 HP (105 kW) @2000 rpm / SAE J1995 (Gross)
Max. Torque	: 550 Nm @1600 rpm (Gross)
Displacement	: 4038 cc
Bore and Stroke	: 101 mm x 126 mm
Emission Class	: Stage V / Tier 4 Final (EU/EPA)

LOWER STRUCTURE (CHASSIS)

Chassis	: Box shaped, reinforced lower chassis, front dozer blade and rear outriggers (stabilizers) as standard figures.
Axles	: The pivot pin mounted front axle allows two options: 8° in each direction for best matching conditions, or could be locked at any desired position for perfect stability.
Tires	: 19,5 - R18 (Single tire) : 10.00 - R20 (Double tire)

CAB

<ul style="list-style-type: none"> • Improved operator's all round visibility • Increased cabin internal space • Use of six silicone dampers to absorb the shocks and vibrations • High capacity A/C • Opera Control System • Cooled storage room • Glass holder, book and object storage pockets • Pool type floor mat • Improved operator's comfort through versatile adjustable seat
--

TRAVEL AND BRAKES

Travel	: Fully hydrostatic
Travel Motors	: Axial piston type
Reduction	: 2 stage planetary gear
Travel Speed	
High Speed	: 37 km/h
Low Speed	: 10 km/h
Max. Drawbar Pull	: 7.380 kqf
Gradeability	: 25° (%47)
Service Brake	: Independent front/rear style (double circuit) hydraulic power brake system. Pressure engaged/spring released type. Located "on hub" for ideal stability and safety.

SWING SYSTEM

Swing Motor	: Axial piston type integrated with shock absorber valves
Reduction	: 2 stage planetary gear box.
Swing Brakes	: Hydraulic multi disc type.
Swing Speed	: 13,8 rpm

LUBRICATION

Centralized lubrication system is provided for lubrication all difficult-to-reach parts on the components, such as boom and arm

HYDRAULIC SYSTEM

Main Pump	
Type	: Double variable displacement axial piston pumps
Max. Flow	: 2 x 160 L/min
Pilot Pump	: 20 L/min
Relief Valves	
Cylinders	: 330 kqf/cm ²
Power Boost	: 360 kqf/cm ²
Travel	: 360 kqf/cm ²
Swing	: 260 kqf/cm ²
Pilot	: 40 kqf/cm ²
Cylinders	
Main Boom	: 2 x ø 110 x ø 75 x 1.080 mm
Stick Cylinder	: 1 x ø 115 x ø 80 x 1.225 mm
Bucket Cylinder	: 1 x ø 100 x ø 70 x 910 mm

OPERA CONTROL SYSTEM

<ul style="list-style-type: none"> • Easy-to-use control panel and menus • Improved fuel economy and productivity • Automatic electric power-off • Selection of multi-language on control panel • Maximum efficiency by selection of power and work modes • Automatic preheating • Anti-theft system with personal code • Hidromek Smartlink (Optional) • Cruise control travel speed • Auto-Idle and automatic deceleration system 	<ul style="list-style-type: none"> • Overheat prevention and protection system without interrupting the work • Automatic powerboost switch-on and switch-off • Maintenance information and warning system • Rear-view, arm-view camera (Optional) • Possibility to register 27 different operating hours • Error mode registry and warning system • Real time monitoring of operational parameters such as pressure, temperature, engine load
---	--

STEERING SYSTEM

The "orbitrol" type steering system controls a steering cylinder located on the front axle.

CAPACITY

Fuel Tank	: 245 L	Engine Cooling System	: 20 L
Hydraulic Tank	: 120 L	Engine Oil	: 16 L
Hydraulic System	: 210 L	Urea tank	: 16 L

ELECTRICAL SYSTEM

Voltage	: 24V
Battery	: 2 x 12V / 100 Ah
Alternator	: 24V / 100 A
Starting Motor	: 24V / 4,0 kW

WEIGHT

Standard machine operating weight	: 16.300 kg
-----------------------------------	-------------

Operational weight, complying with the ISO 6016 standards, includes full fuel tank, hydraulic system and other liquids, 75kg operator weight and standard equipped machine weight. Optional equipments are not included.

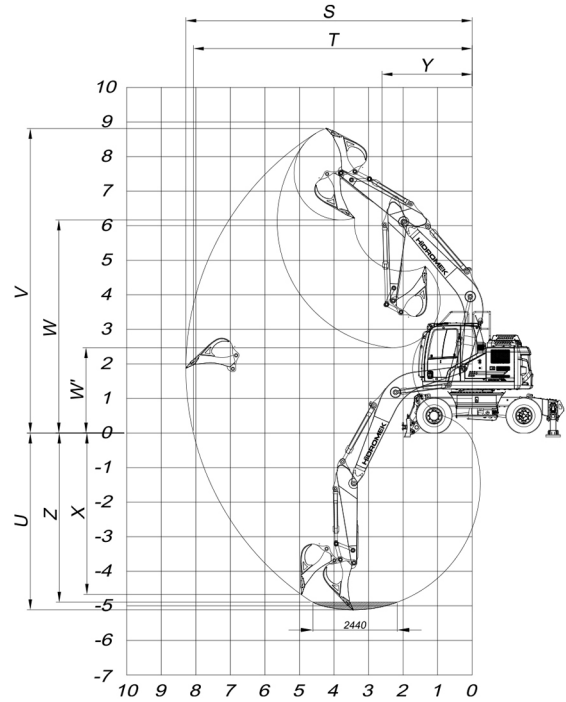
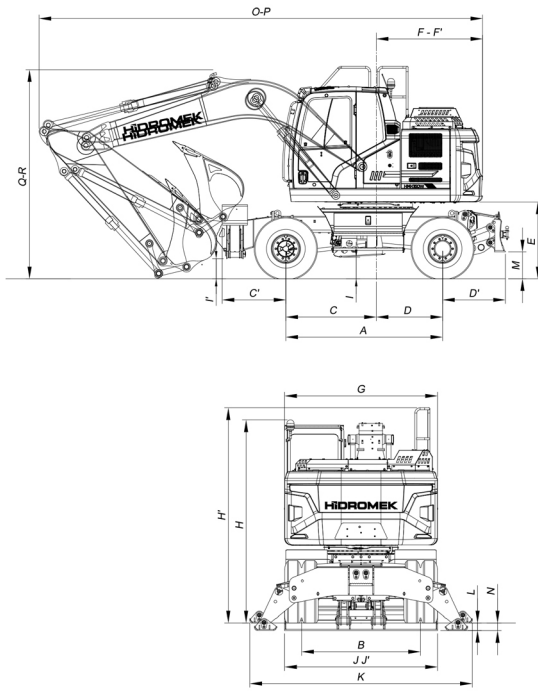

GENERALE DIMENSIONS

Boom Dimension	4.600 mm			
Arm Dimension	2.000 mm	*2.300 mm	2.600 mm	2.900 mm
A - Axle Distance	2.600 mm			
B - Thread	1.944 mm			
C - Rotation Axis – Front Axle Distance	1.500 mm			
C' - Front Axle to Front Outrigger maximum distance	1.055 mm			
D - Rotation Axis – Rear Axle Distance	1.100 mm			
D' - Rear Axle Rear to Dozer Blade distance	1.073 mm			
E - Upper Chassis to Ground Clearance	1.270 mm			
F - Counterweight Distance	1.765 mm			
F' - Counterweight Turning Radius	1.850 mm			
G - Upper Frame Width	2.500 mm			
H - Cab Height	3.340 mm			
I - Outrigger Ground Clearance	355 mm			
J - Width at Tires	2.500 mm			
J' - Overall tire width (Loaded)	2.550 mm			
K - Outrigger Width (Overall)	3.634 mm			
L - Outrigger Digging Depth	122 mm			
M - Dozer Blade Ground Clearance	447 mm			
N - Dozer Blade Digging Depth	124 mm			
O - Overall Length / Travel	7.360 mm	7.360 mm	7.280 mm	6.920 mm
P - Overall Length/ Transport	7.400 mm	7.290 mm	7.280 mm	7.180 mm
Q - Boom Height / Travel	3.220 mm	3.470 mm	3.730 mm	4.180 mm
R - Boom Height / Transport	3.220 mm	3.400 mm	3.570 mm	3.750 mm

WORKING DIMENSIONS

S - Maximum Digging Reach	7.940 mm	8.220 mm	8.520 mm	8.810 mm
T - Maximum Digging Reach at Ground Level	7.710 mm	8.000 mm	8.310 mm	8.600 mm
U - Maximum Digging Depth	4.740 mm	5.040 mm	5.340 mm	5.640 mm
V - Maximum Digging Height	8.580 mm	8.760 mm	9.000 mm	9.180 mm
W - Maximum Dumping Clearance	6.060 mm	6.240 mm	6.470 mm	6.660 mm
W' - Minimum Dumping Clearance	2.840 mm	2.540 mm	2.250 mm	1.940 mm
X - Maximum Vertical Digging Depth	4.270 mm	4.560 mm	4.860 mm	5.150 mm
Y - Minimum Swing Radius	2.580 mm	2.620 mm	2.670 mm	2.690 mm
Z - Maximum Digging Depth (2440 mm level)	4.490 mm	4.820 mm	5.140 mm	5.450 mm

DIGGING PERFORMANCE

Standard Bucket Capacity (SAE)	0,6 m ³	0,6 m ³	0,6 m ³	0,6 m ³
Bucket Digging Force (Power Boost) ISO	9.900 (10.800) kgf	9.900 (10.800) kgf	9.900 (10.800) kgf	9.900 (10.800) kgf
Arm Crowd Force (Power Boost) ISO	7.800 (8.600) kgf	7.100 (7.800) kgf	6.500 (7.100) kgf	6.000 (6.500) kgf

* Standard

HİDROMEK®

FACTORY - HEAD OFFICE

Ahi Evran OSB Mahallesi Osmanlı Caddesi No:1 06935 Sincan / ANKARA / TURKEY
Tel: (+90) 312 267 12 60 Fax: (+90) 312 267 12 39
www.hidromek.com

Notice:
Hidromek has the right to modify the specifications and design of the model indicated on this brochure without prior notice.