

TAKEUCHI

From World First to World Leader

HUPPDUMP D601APG



D 601 APG

TECHNICAL DATA

GENERAL		D 601 APG
Unloading system	-	Rotating
Load capacity	kg	6000
Chassis	-	Articulated and oscillating
Water hopper capacity	l	1665
Level hopper capacity	l	2455
Heaped hopper capacity	l	3154
Empty weight	kg	4696
Transmission	-	Powershuttle
ENGINE		
Brand	-	DEUTZ
Model	-	TD 3.6 L4
Power	kW	55,4
Operating speed	rpm	2200
Torque	N·m@rpm	340@1500
No. of cylinders	-	4
Emissions	-	Stage V, Tier 4f
Injection	-	Common Rail
Exhaust aftertreatment	-	DPF (Diesel particulate filter)
Noise	dB(A)	101
DRIVING		
Max. speed	km/h	25
Maximum gradient	%	45
External turning radius	mm	5900
Traction	-	4x4
Tyres	-	405/70-20"
HYDRAULIC SYSTEM		
Hydraulic circuit	-	23 cc double gear pump
Flow rate	l/min	46
Working pressure	bar	180
TANK CAPACITY		
Fuel	l	69
Hydraulic system	l	60
BRAKES		
Service	-	Sealed brakes with multiple discs in oil. Hydraulic drive
Parking	-	Sealed brakes with multiple discs in oil. Negative

DIMENSIONS

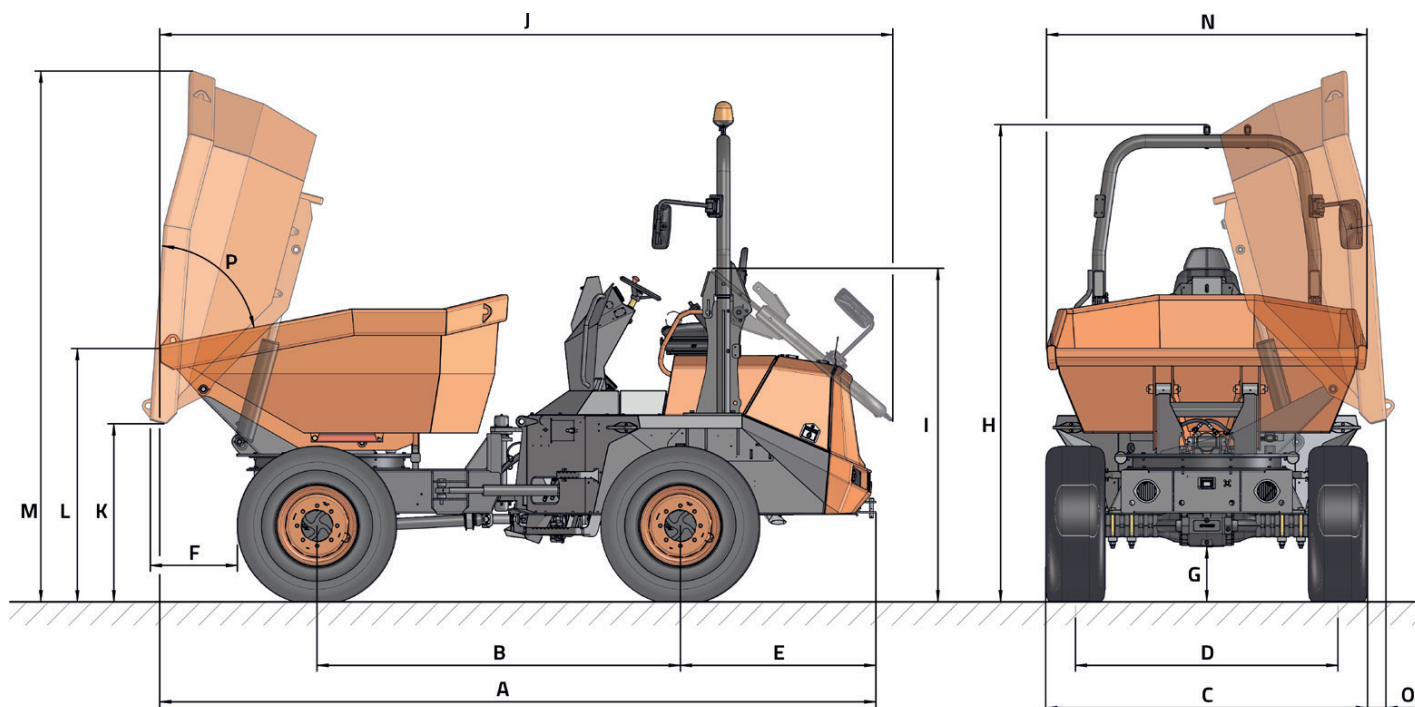

DIMENSIONS (mm)	D 601 APG
A	4910
B	2490
C	2210
D	1800
E	1340
F	580
G	380
H	3280 (3110*)
I	2290
J	5030
K	1220
L	1740
M	3640
N	2200
O	110
DIMENSIONS (°)	
P	75



takeuchi@hidro-rad.hr



+(385) 21 721 041