

TAKEUCHI

From World First to World Leader

HUPPDUMP D1001APG



D 601 APG

TECHNICAL DATA

GENERAL		D 1001 APG
Unloading system	-	Rotating
Load capacity	kg	10000
Chassis	-	Articulated and oscillating
Water hopper capacity	l	1850
Level hopper capacity	l	3300
Heaped hopper capacity	l	3900
Empty weight	kg	5185
Transmission	-	Torque converter
ENGINE		
Brand	-	DEUTZ
Model	-	TCD 3.6 L4 HT
Power	kW	55,4
Operating speed	rpm	2200
Torque	N·m@rpm	405@1300
No. of cylinders	-	4
Emissions	-	Stage V
Injection	-	Common Rail
Exhaust aftertreatment	-	DPF (Diesel particulate filter)
Noise	dB(A)	100,6
DRIVING		
Max. speed	km/h	25
Maximum gradient	%	45
External turning radius	mm	6287
Traction	-	4x4
Tyres	-	500/60-22.5
HYDRAULIC SYSTEM		
Hydraulic circuit	-	Double gear pump
Flow rate	l/min	46
Working pressure	bar	180
TANK CAPACITY		
Fuel	l	69
Hydraulic system	l	60
BRAKES		
Service	-	Sealed brakes. Hydraulic drive
Parking	-	Sealed brakes. Negative

DIMENSIONS

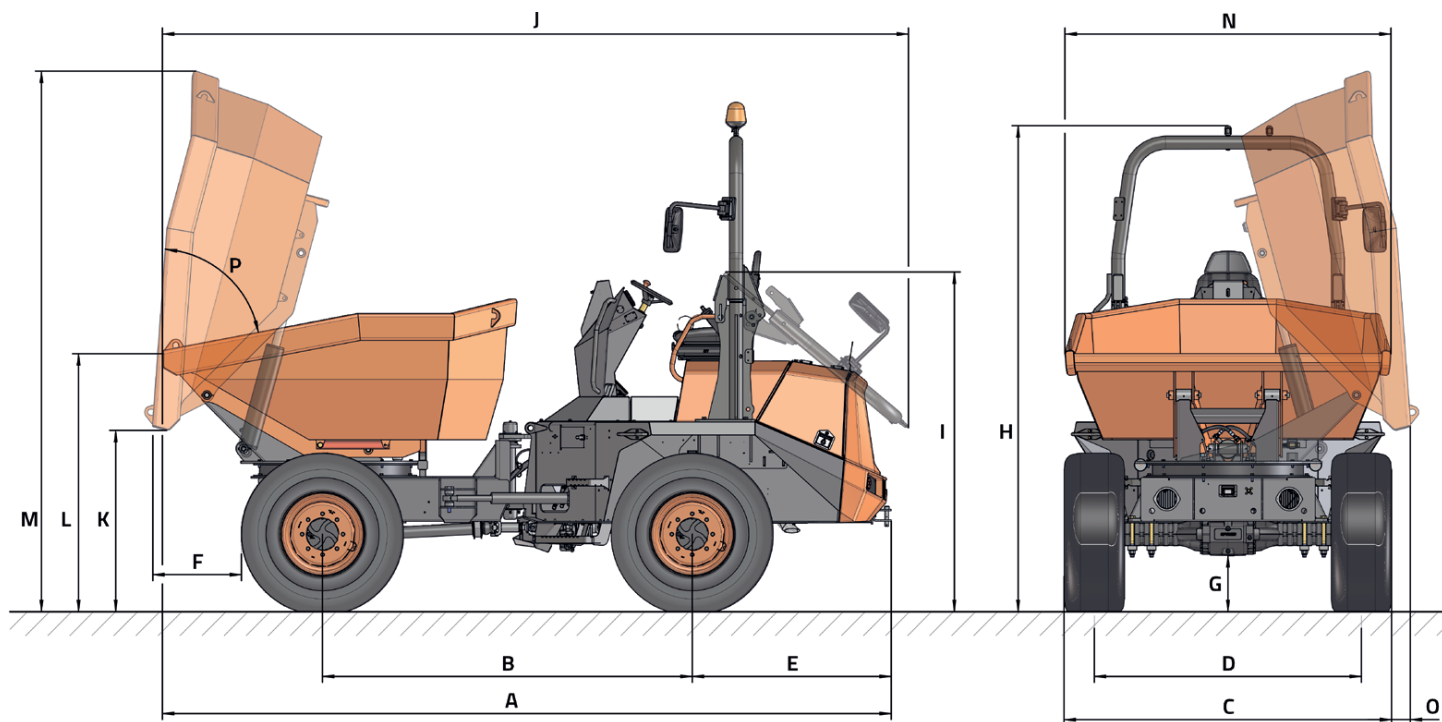

DIMENSIONS (mm)

D 1001 APG

	5020
	2690
	2410
	1920
	1340
	485
	410
	3640 (3470*)
	2560
	5140
	1260
	1820
	3830
	2330
	155
DIMENSIONS (°)	
	75



takeuchi@hidro-rad.hr



+ (385) 21 721 041