



ENGINE

Model	: ISUZU AJ-4JJ1X
Type	: Water cooled, 4 cycle, 4 cylinders, line type direct injection, turbocharger, intercooler, electronic diesel engine
Power	: 98 HP (73 kW) @2000 rpm / SAE J1995 (Gross) : 95 HP (70,9 kW) @2000 rpm / SAE J1349 (Net)
Max. Torque	: 385 Nm @1600 rpm (Gross) : 378 Nm @1600 rpm (Net)
Displacement	: 2999 cc
Bore and Stroke	: 95,4 mm x 104,9 mm
Emission Class	: Stage IIIA / Tier 3 (EU/EPA)

UNDERCARRIAGE

X Type Lower Frame Construction Pentagon Box Type Chassis	
Shoe	: Triple grouser - 500 mm
No. Of Shoes	: 2 x 46
No. Of Lower Rollers	: 2 x 7
No. Of Upper Rollers	: 2 x 2
Track Tensioning	: Hydraulic Spring Tensioning
Dozer Blade (Optional)	

CAB

<ul style="list-style-type: none"> Improved operator's all round visibility Increased cabin internal space Use of six viscomount cabin mountings that dampen the vibrations High capacity A/C High resolution, led backlight, color LCD display Opera Control System Cooled storage room Glass holder, book and object storage pockets Pool type floor mat Improved operator's comfort through versatile adjustable seat Ergonomically redesigned cabin through relocated switch board, and re-styled travel pedals and joysticks.

TRAVEL AND BRAKERS

Travel	: Fully hydrostatic
Travel Motors	: Axial piston type
Reduction	: 2 stage planetary gear
Travel Speed	
High Speed	: 5,6 km/h
Low Speed	: 3,3 km/h
Max. Drawbar Pull	: 11.385 kqf
Gradeability	: 35° (%70)
Parking Brake	: Hydraulic multi disc type
Ground Pressure	: 0,44 kqf/cm ²

LUBRICATION

Centralized lubrication system is provided for lubrication all difficult-to-reach parts on the components, such as boom and arm

HYDRAULIC SYSTEM

Main Pump	
Type	: Double variable displacement axial piston pumps
Max. Flow	: 2 x 129 L/min
Pilot Pump	: Gear, 20 L/min
Relief Valves	
Attachment	: 320 kgf/cm ²
Power Boost	: 350 kgf/cm ²
Travel	: 350 kgf/cm ²
Swing	: 300 kgf/cm ²
Pilot	: 40 kgf/cm ²
Cylinders	
Main Boom	: 2 x ø 110 x ø 75 x 1.080 mm
Stick Cylinder	: 1 x ø 115 x ø 80 x 1.225 mm
Bucket Cylinder	: 1 x ø 100 x ø 70 x 910 mm

OPERA CONTROL SYSTEM

<ul style="list-style-type: none"> Easy-to-use control panel and menus Overheat prevention and protection system without interrupting the work Automatic electric power-off Maximum efficiency by selection of power and work modes Error mode registry and warning system 	<ul style="list-style-type: none"> Improved fuel economy and productivity Automatic idling Selection of multi-language on control panel Rear-view, arm-view camera (Optional) Possibility to register 27 different operating hours Anti-theft system with personal code Real time monitoring of operational parameters such as pressure, temperature, engine load
<ul style="list-style-type: none"> Hidromek Smartlink (Optional) Automatic preheating Automatic powerboost 	

SWING SYSTEM

Swing Motor	: Axial piston type integrated with shock absorber valves
Reduction	: 2 stage planetary gear box.
Swing Brakes	: Hydraulic multi disc type, automatic warnings
Swing Speed	: 11,1 rpm

CAPACITY

Fuel Tank	: 280 L	Engine Oil	: 16 L
Hydraulic Tank	: 115 L	Radiator	: 20 L
Hydraulic System	: 210 L		

ELECTRICAL SYSTEM

Voltage	: 24V
Battery	: 2 x 12V x 100 Ah
Alternator	: 24V / 50 A
Starting Motor	: 24V / 4 kW

OPERATING WEIGHT

Standard machine operating weight	: 15.650 kq
-----------------------------------	-------------

Operational weight, complying with the ISO 6016 standards, includes full fuel tank, hydraulic system and other liquids, 75 kg operator weight and standard equipped machine weight. Optional equipments are not included.

HMK140LC H4

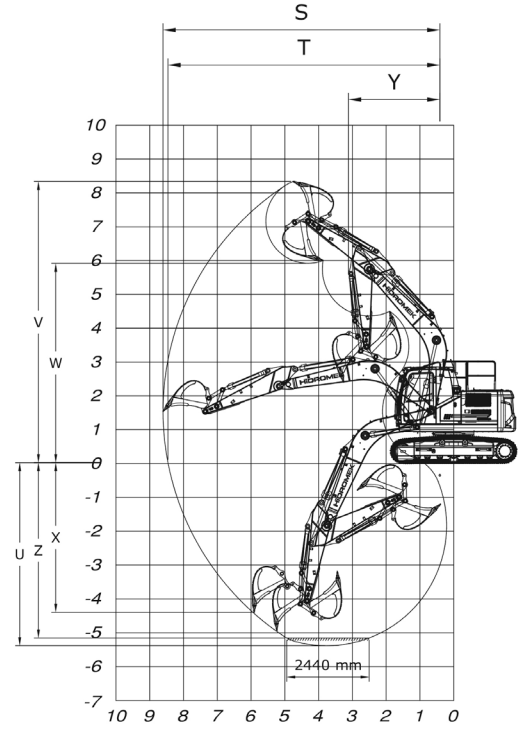
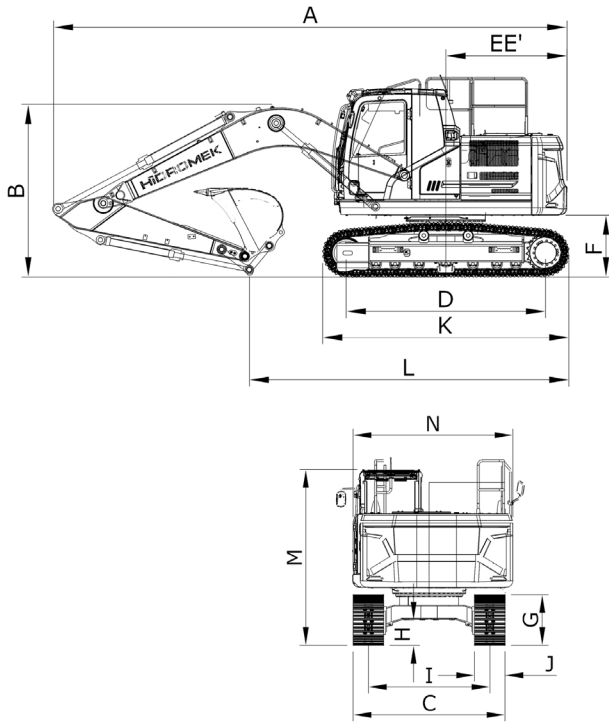

GENERAL DIMENSIONS

Boom dimension	4.600 mm		
Arm dimension	*2.300 mm	2.600 mm	2.900 mm
A - Overall length	7.890 mm	7.890 mm	7.870 mm
B - Overall height(to top of boom)	2.830 mm	2.950 mm	3.030 mm
C - Overall width (of lower structure)	2.490 mm		
D - Idler distance	3.035 mm		
E - Tall swing radius	2.245 mm		
E' - Tall swing distance	2.265 mm		
F - Upperstructure ground clearance	940 mm		
G - Crawler height	830 mm		
H - Min. Ground clearance	430 mm		
I - Track gauge	1.990 mm		
J - Shoe width	500 mm		
K - Overall length of crawler	3.780 mm		
L - Length over ground	4.650 mm	4.500 mm	4.260 mm
M - Overall height(to top of cab)	2.880 mm		
N - Upperstructure width	2.500 mm		

* Standard

WORKING DIMENSIONS

Boom dimension	4.600 mm		
Arm dimension	*2.300 mm	2.600 mm	2.900 mm
S - Max.digging reach	8.220 mm	8.520 mm	8.810 mm
T - Max.digging reach at ground level	8.070 mm	8.380 mm	8.670 mm
U - Max.digging depth	5.360 mm	5.660 mm	5.960 mm
V - Max.digging height	8.430 mm	8.680 mm	8.860 mm
W - Max.dumping height	5.920 mm	6.150 mm	6.330 mm
W' - Min.dumping height	2.220 mm	1.920 mm	1.610 mm
X - Max.vertical digging depth	4.890 mm	5.180 mm	4.480 mm
Y - Min. swing radius	2.620 mm	2.670 mm	2.690 mm
Z - Max. digging depth(2440mm level)	5.140 mm	5.460 mm	5.780 mm

* Standard

DIGGING PERFORMANCE

Standard Bucket Capacity (SAE)	0,6 m ³
Bucket Digging Force(Power Boost) ISO	9.600 (10.500) kqf
Arm Crowd Force(Power Boost) ISO	6.900 (7.600) kqf



HİDROMEK®

FACTORY - HEAD OFFICE

Ahi Evran OSB Mahallesi Osmanlı Caddesi No:1 06935 Sincan / ANKARA / TURKEY
Tel: (+90) 312 267 12 60 Fax: (+90) 312 267 12 39
www.hidromek.com

Notice:
Hidromek has the right to modify the specifications and design of the model indicated on this brochure without prior notice.